

100-5010 TriGuard Heavy-Duty Door Hardware Module V1

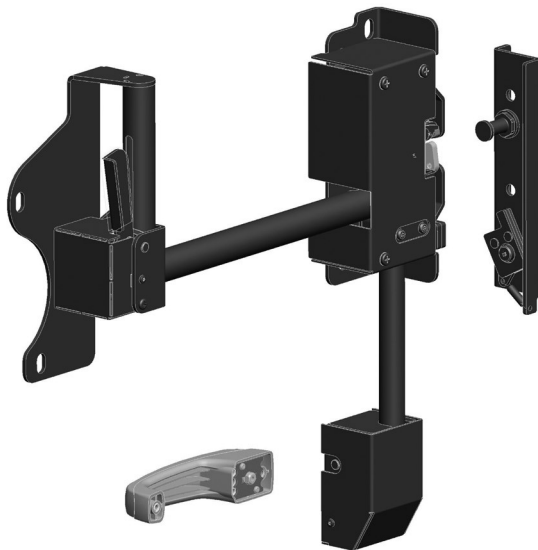

This robust door hardware kit features modular construction that allows for simple customization, including remote or integrated exterior handle placement to accommodate variable door sizes. Designed for medium to heavy duty doors of 23-455kg (50-1000 lbs.) for entrance and rear door applications. The kit also allows for a minimum of assembly fasteners as well as providing a support system when adding significantly more weight to the door such as up-armoring existing doors.

FEATURES/BENEFITS:

- Heavy duty modular construction is received fully assembled and tested
- Cuts door assembly time by as much as 50% to 70% □□ improving vehicle cost and throughput
- Improved serviceability in the field and ability to retrofit into existing applications
- Interior locking mechanism provides additional safety for occupants
- Single motion egress
- Integrated weight support system
- Incorporates TriMark's proven 050-0850 Heavy Duty Latch



TriMark. Interactive. Product. Selector

Global Locations:

TriMark Corporation
500 Bailey Avenue
P.O. Box 350
New Hampton, Iowa 50659
United States
Tel: 641-394-3188
Fax: 641-394-2392
1-800-447-0343
www.trimarkcorp.com

TriMark Europe
Cedar Court
Walker road
Bardon Hill
Coalville LE67 1TU
United Kingdom
Tel: +44(0)1530 512460
Fax: +44(0)1530 512461
www.trimarkeu.com

TriMark (Xuzhou)
Building A5 Jingwu Road
Xuzhou Economic
Development Zone
Xuzhou, Jiangsu
221004 PR China
Tel: +86 516 8773 0018
Fax: +86 516 8773 0058
www.trimarkcn.com



TriMark



TriMark Corporation

AVAILABLE:

- Remote or integrated exterior handle options (remote version shown)
- Right or left hand versions
- Customization features available. Please inquire:
 - ◆ Mounting details
 - ◆ Length of grab bar
 - ◆ Exterior handle location

MATERIAL:

- Standard—high strength steel construction
- Available with advanced lightweight aluminum alloy

FINISH:

- Standard low gloss black powder coated
- Mil-Spec soft grip nylon coated handle
- 1000 hour corrosion protection
- Optional finishes available including: Black Magni™ coating, Tan/Olive CARC paint and Tan/Olive powder coating

INSTALLATION:

- Easy to install, mounts with (4) M10 X 1.75 fasteners and (3) M6 X 1.0 fasteners
- Tighten to the manufacturers' recommended torque value

Individual part dimensions are for reference only. Refer to individual part drawings for complete dimensions, specifications, and installation procedures. Engineering assistance and application drawings are available.

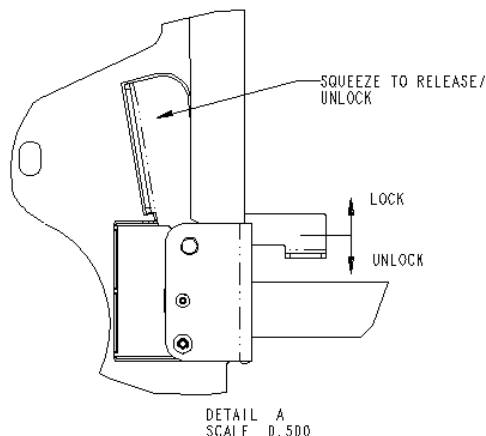
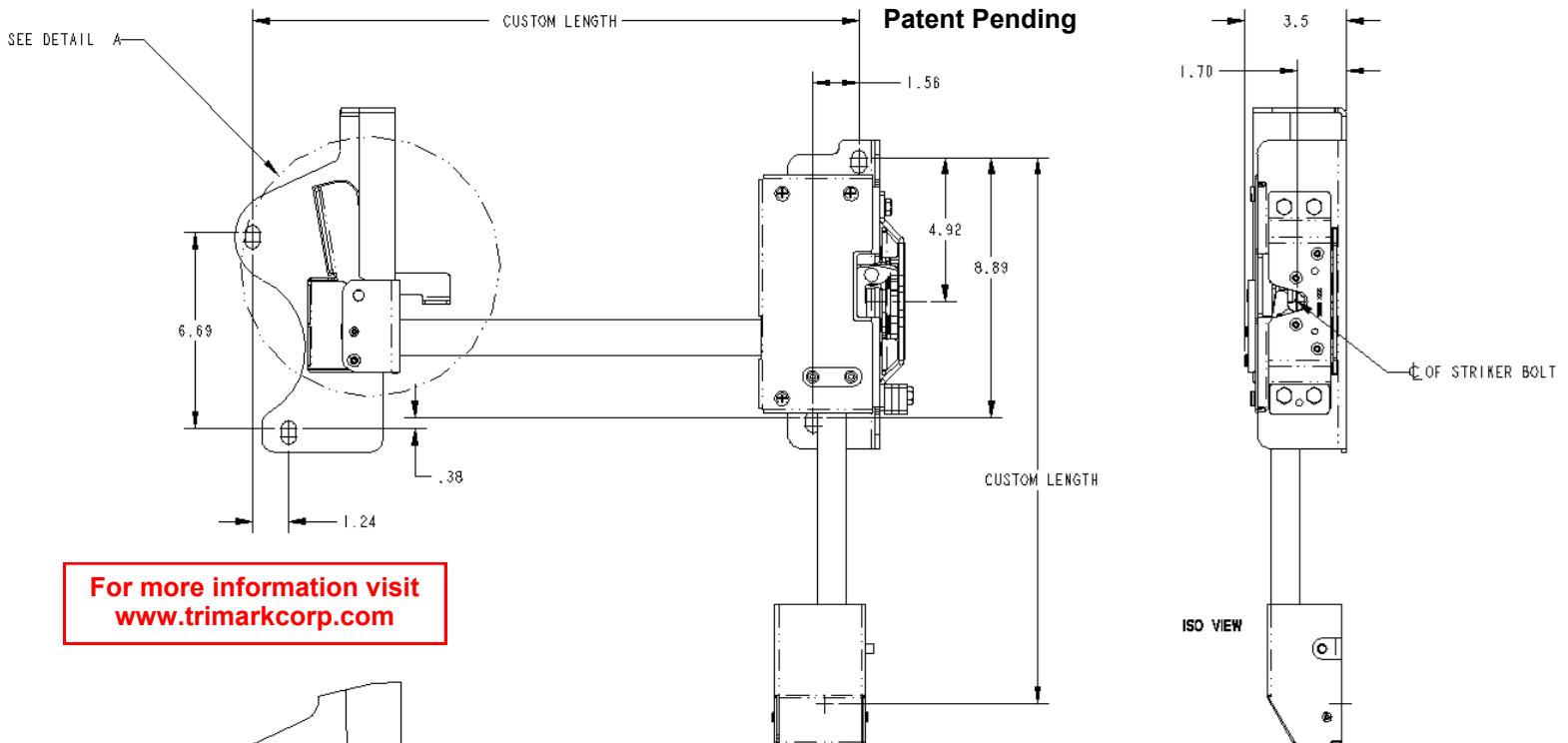

CAUTION: Applications of this system may fall within the requirements of FMVSS 206 (ECE R11) and SAE J839 safety standards. These safety related requirements are dependent on door application, e.g. front and rear hinged doors, sliding doors, or hinged upward swinging doors. The entire door hardware system must be included in the design/analysis process latch, handle, lock mechanism, rods/linkages, fasteners, hinges, etc. This ensures compatibility of all components within the hardware system. If FMVSS 206 (ECE R11) is a requirement, then all of the components within the door system must comply with strength, inertia and locking requirements as specified within the Standard. Note that this product complies with FMVSS 206 (ECE R11) when tested in accordance with SAE J839 and that this system meets FMVSS 206 (ECE R11) loads and locking requirements and may be used in FMVSS 206 (ECE R11) applications pending TriMark application approval.